

Patented Features

- Opposing eccentric reamers with pdc cutters force each other into the formation
- Eccentric design enlarges bore hole drift to 1/16" or 1/8" over bit size
- Progressive blades incrementally shear the formation
- Diamond domes protect the pipe and pdc cutters when rotating in casing
- Profile relief draws formation into pdc cutters more efficiently

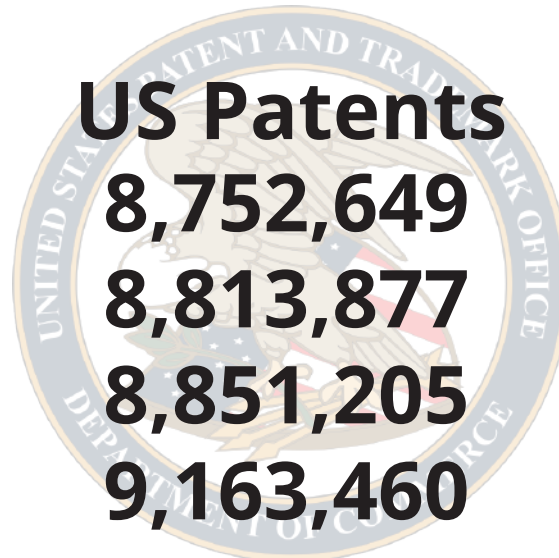

Technical Specifications

Tool Size (ID)	1 1/2" - 3 3/4" *
Tool Size (OD)	4 3/4" - 14 3/4" **
Length	8'-10'
Weight	350-1,200 lbs.
Connections	Any
Max Pull	Thread Dependent

*Tools can be customized for each application
 **Tools supplied in 1/16" increment ranges



Contact
Superior Drilling Products
435-789-0594
SDPI.com



DRILL-N-REAM[®]



Improves Well Bore Quality

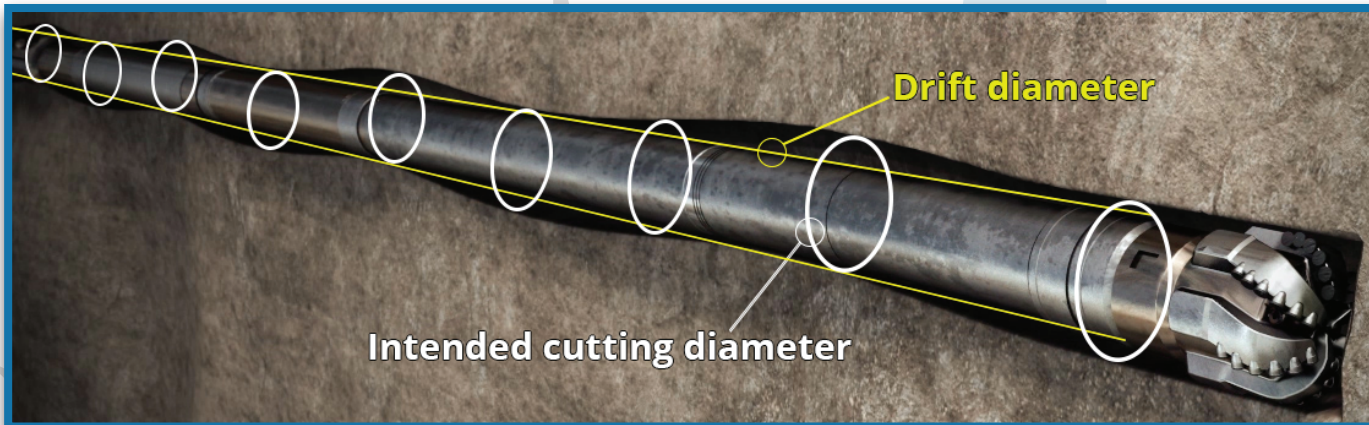

Check one to optimize your drilling operation:

- Eliminate dedicated reamer runs
- Reduce torque and drag
- Lessen hook loads
 - Shorten trip times
 - Slash bead and mud friction reducer usage
- Diminish downhole vibration
- Enhance weight transfer to bit
 - Elevate rate of penetration
 - Improve differential pressure
 - Minimize mud motor failures
 - Lower mechanic specific energy
 - Increase bit life

